



40 GHz SMA-2.9 N/O S.P.4 T. SWITCH

OPTIONS : INDICATOR

R F CHARACTERISTICS

NUMBER OF WAYS : 4
FREQUENCY RANGE : 0 - 40 GHz
IMPEDANCE : 50 Ohms

FREQUENCY (GHz)	0 - 6	6 -12.4	12.4- 18	18 -26.5	26.5- 40
V.S.W.R <=	1.30	1.40	1.50	1.70	2.20
INSERT. LOSS <=	0.20 dB	0.40 dB	0.50 dB	0.70 dB	1.10 dB
ISOLATION >=	70 dB	60 dB	60 dB	55 dB	50 dB
AVER. POWER (*)	40 W	30 W	25 W	15 W	5 W

ELECTRICAL CHARACTERISTICS

ACTUATOR : NORMALLY OPEN
NOMINAL CURRENT AT 25° C (±10%) : 102 mA
ACTUATOR VOLTAGE (Vcc) : 28V (24 to 30V) / POSITIVE COMMON
TERMINALS : solder pins (250°C max./30 sec.)
INDICATOR RATING : 1 W / 30 V / 100 mA

MECHANICAL CHARACTERISTICS

CONNECTORS : SMA 2.9 fem.per MIL C 39012
LIFE : 2.000.000 cycles per position
SWITCHING TIME (nominal voltage;25° C) : < 15 ms
CONSTRUCTION : splashproof
WEIGHT : < 180 g

ENVIRONMENTAL CHARACTERISTICS

OPERATING TEMPERATURE RANGE (°C) : -40 , +85
STORAGE TEMPERATURE RANGE (°C) : -55 , +85

(* : average power at 25° C per RF path)

This information is given as an indication. In the continual goal to improve our products, we reserve the right to make any modifications judged necessary

4113-9212 This information is given as an indication. In the continual goal to improve our products, we reserve the right to make any modifications judged necessary

DRAWING

General tolerance: ± 0,5 mm

R573 813410

Page
2/2

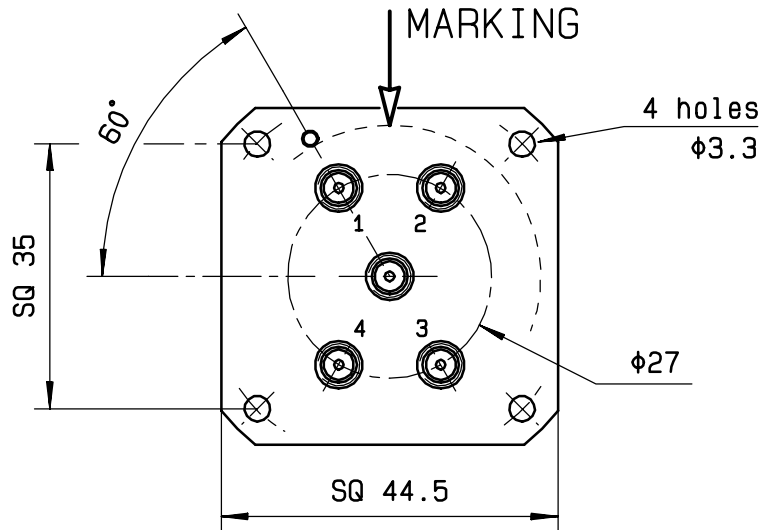

Voltage	RF continuity	Ind.
+C -1	IN ↔ 1	D.E
+C -2	IN ↔ 2	D.F
+C -3	IN ↔ 3	D.G
+C -4	IN ↔ 4	D.H

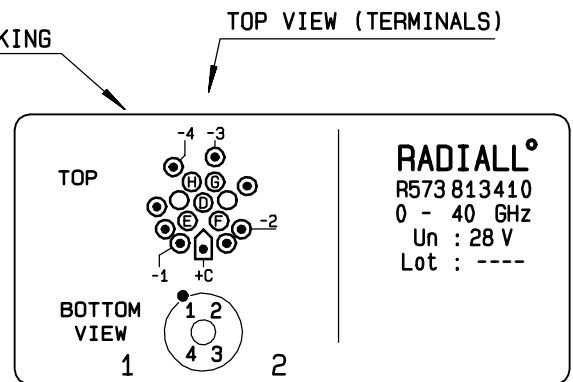
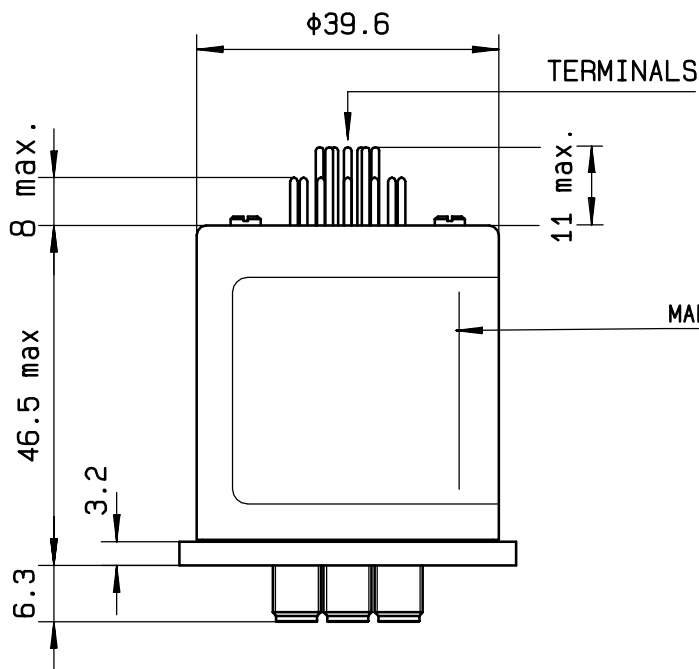

SCHEMATIC DIAGRAM

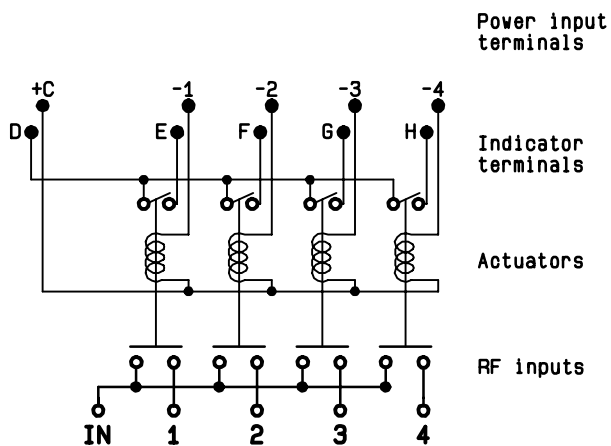

ISSUE 22.Jan.08